

4 Units - 3 Configuration Options

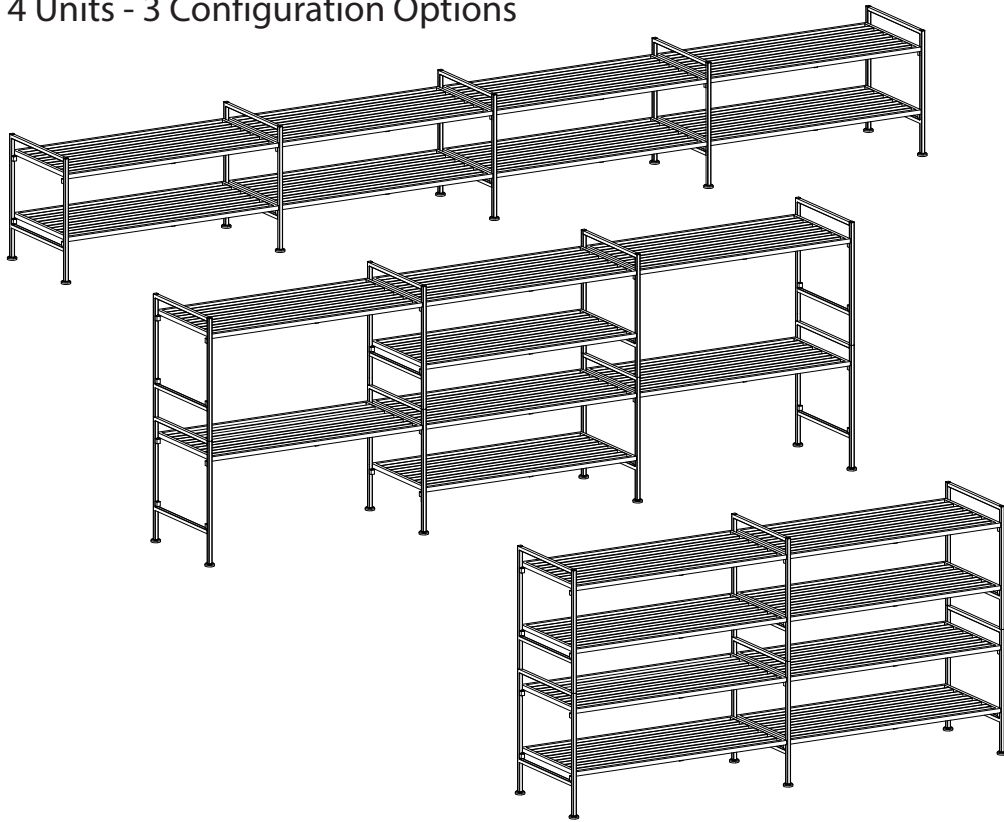

#15894/WEB211

2-TIER UTILITY SHOE/STORAGE RACK ASSEMBLY INSTRUCTIONS

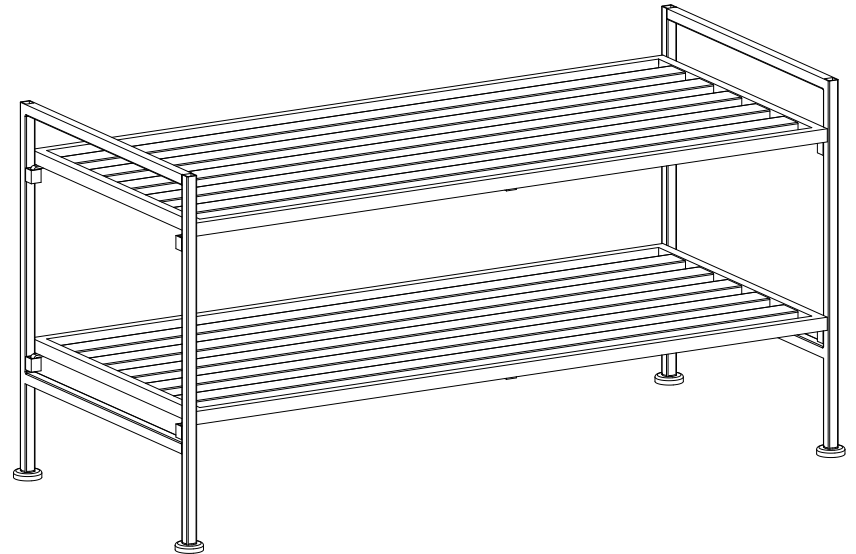

WARNING: Do not sit on the rack. Do not drop heavy items on the rack. Place heavier items on the lower shelves and lighter ones on the top shelves. Do not move the rack while loaded. Do not move the rack by lifting the shelf, use the handles instead.

WEIGHT CAPACITY: 25 lb per shelf



CUSTOMER SERVICE

Tel 1.310.533.3800

Monday through Friday

8:30am - 4:30pm (Pacific Time)

www.sevilleclassics.com

CUSTOMER SERVICE

Tel 1.310.533.3800

Tel 1.800.323.5565

Fax 1.310.533.3899

Monday through Friday

8:30 am - 4:30 pm (Pacific Time)



Seville Classics, Inc.

Torrance, CA 90501 USA

www.sevilleclassics.com

Please Read and Save These Instructions

US & International Patents Pending ©2013 Seville Classics, Inc.

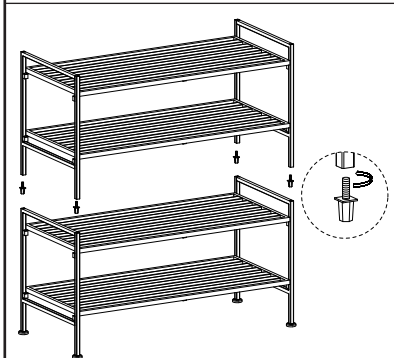
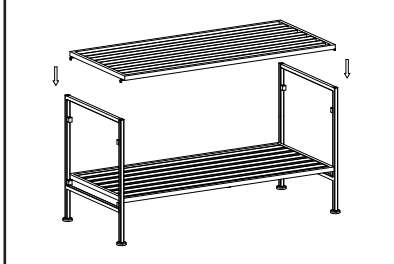
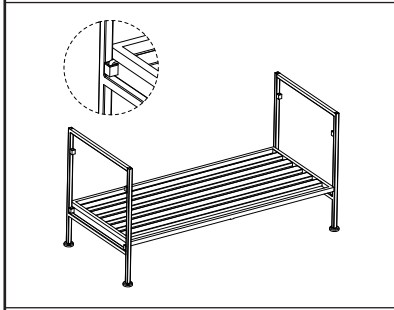
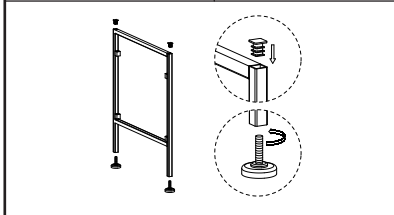
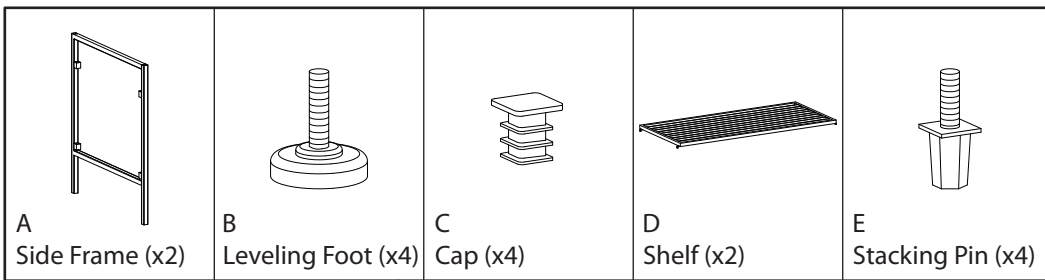

NOTE: Drawing shows 2 units stacked vertically. Do not exceed maximum height of 2 stacked units.

STEPS TO ASSEMBLE THE RACK

1. Unpack and remove all parts from the box. If there are missing or broken parts, please contact CUSTOMER SERVICE.
2. Screw the LEVELING FEET (B) into the legs of each SIDE FRAME (A). Insert the CAPS (C) into the top holes of each side frame.
3. Lean one side frame against a non-scratchable surface (e.g., a wall) and insert the hooks on both sides of the SHELF (D) into the lower brackets of the side frames. It's easier to attach the bottom shelf first especially if you keep one of the side frames pressed firmly against a non-scratchable surface (e.g., a wall).
4. While keeping one side frame pressed firmly against a non-scratchable surface (e.g., a wall), repeat step 3 for the second (top) shelf.
5. Ensure the hooks on both shelves are firmly inserted into both side frames. Once all shelves are securely in place, adjust the leveling feet by screwing them in or out to obtain a level rack.

STEPS TO STACK THE RACK

1. Build another rack following the instructions above. However, do not install the LEVELING FEET (B) on the second (top) unit.
2. Screw the STACKING PINS (E) into the legs of the top unit. Remove all CAPS (C) from the original (base) unit.
3. Lift the top unit up and onto the base unit, lining up the pins with the holes at the four top corners so that they can be inserted into each other. Be sure everything is in alignment and then press down firmly on the top unit so that it fits tightly into and onto the base unit.

Scan code or visit link to view an assembly video:
youtu.be/Nyc05rL2iyw



INTERLOCK™

Building a modular shelving system, horizontally interlock multiple units by attaching the shelves to the side frames of corresponding units.

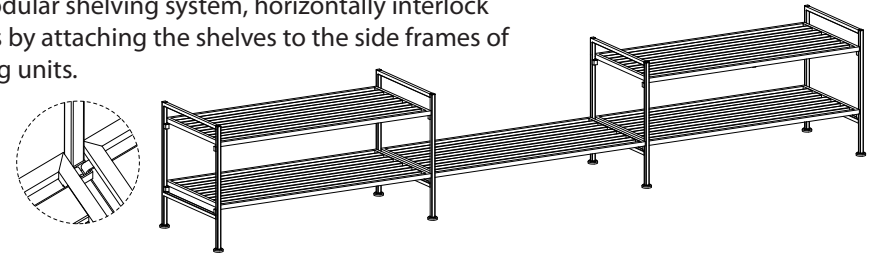

2 Units - 2 Configuration Options

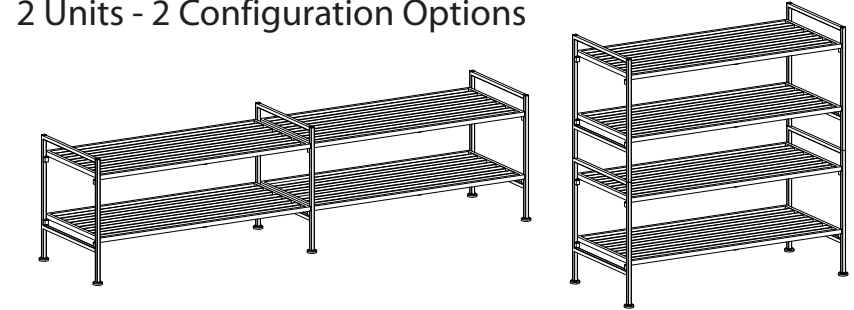

3 Units - 3 Configuration Options

