

Worksmen Adaptable Industrial Tricycle Owner's Manual

Worksmen Trading Corporation . 94-15 100th Street . Ozone Park, NY 11416 . (718) 322-2000

www.worksmancycles.com

Parts list ADPT09

Models ADP, ADB, ADC, ADBB, -CB, -3CB, -NDB



Worksmen Adaptable Tricycles - The World's Original Industrial Tricycle

Congratulations! You have purchased a true industrial tricycle . the Worksman Adaptable Industrial Tricycle. The Adaptable is considered the father of the Worksman Business Cycle System, which is undoubtedly the finest line of industrial cycles. These durable tricycles are used around the world by leading companies and organizations to move personnel and supplies efficiently and safely in an environmentally friendly manner.

Before assembling and riding, make certain to read this manual and any other literature provided thoroughly. Always follow the rules of safe riding. Always keep your Adaptable tricycle in tip-top shape by replacing worn parts as needed with genuine Worksman Cycles parts. (Do not use generic bicycle parts.) With simple maintenance, your Worksman Adaptable Tricycle will perform reliably day after day, year after year.

- *This manual is intended as an assembly and maintenance guideline for a professional and qualified bicycle mechanic. Failure to have this cycle professionally assembled could result in injury or death.*

Worksmen Adaptable Parts List (For all freewheel, coaster brake and three-speed coaster brake Adaptable Tricycles.)

Frame, Fork and Related Parts

<u>Part #</u>	<u>Description</u>	<u>Part #</u>	<u>Description</u>
72ACB	Adaptable Frame (Specify color)	60STR	Fork Strap for Drum Brake
60HD	Fork w/ Drum Brake Tab - Black	60HD-YEL	Fork w/ Drum Brake Tab - Safety Yellow
60HD-ORG	Fork w/ Drum Brake Tab - Safety Orange	60HD-SP	Fork w/ Drum Brake Tab - Special color
66HD	Fork w/o Drum Brake Tab - Black	66HD-YEL	Fork w/o Drum Brake Tab . Safety Yel
66HD-ORG	Fork w/o Drum Brake Tab - Safety Org	66HD-SP	Fork w/o Drum Brake Tab - Special
48	Headset Cups (pair)	49	Headset Bearings (pair)
50A	Headset Complete (48,49,52,53,54)	51	Bottom Cone (Presses on fork)
52	Top Adjusting Cone (threaded)	53	Key Washer
54	Fork Top Lock nut	55F	Handlebar - Junior High Rise
55A	Stem	55B	Handgrips (pair)

Front Drum Brake Parts (Old style hubs have loose bearings. New style hub has pressed bearings.)

<u>Part #</u>	<u>Description</u>	<u>Part #</u>	<u>Description</u>
<u>OLD STYLE</u>			
L900	Drum Brake Hub	L709	Front Axle Set for Drum Brake
F817	Wheel Bearings - Loose 11 balls	L725	Drum Brake Plate Kit (Internal parts kit)
<u>NEW STYLE</u>			
L500-F	Hub - NEW STYLE w/ pressed bearing	L509	Axle - NEW STYLE for pressed bearing
L517	Pressed Bearing - NEW STYLE	L525	Drum Brake Plate Kit (NEW STYLE)
F719	Drum Brake Cable w/ F769 and F770	F816	Axle Washer
F769	Anchor Bolt Assembly for F719 Cable	F770	Adjusting Barrel for F719 Cable
L752R	Brake Lever (Right) w/ Parking Lock	160B	Fork Retention Clip (each)
L752L	Brake Lever (Left) w/ Parking Lock	L815	Outside Axle Nut (each)

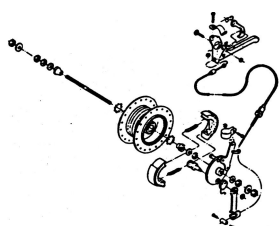

L900 Drum Brake - Exploded View with F719 Cable

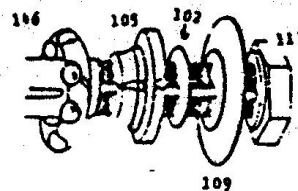

Free Side Rear Wheel - Exploded View

Rear Axle and Related Parts

<u>Part #</u>	<u>Description</u>	<u>Part #</u>	<u>Description</u>
101	Hub for Free Wheel w/ Cups	102	Key Lock Washer
103	Cups for 101 Hub	105	Adjusting Cone (threaded)
106	Stationary Cone (presses onto axle)	109	Dust Washer
113	Locknut - Left Hand Thread - Free Wheel Side	146	Wheel Bearings (pair)
130	Axle Parts Set (102,105,109,113,146,59A,93D)	58A	Rear Axle (31 1/2+)
3980	Drive Wheel Hub	58	Rear Axle (34+. Pre 1965)
59A	Locknut - Drive Side	69	Fixed Drive Sprocket
4129	Freewheel Sprocket (22 tooth)	63A	Bushing for 4129 (freewheel models)
63B	Set screw for 69 and 4129	63C	Keyway for Rear Sprocket
91	Pillow Block Bearings (each)	91A	Bolt, Nut, Washer for 91 Bearing
93	Spacer Washer for Left Side Wheel	93D	Washer . Drive Side Spacer
301	1 Speed Coaster Brake Hub	404N	3 Speed Coaster Brake Hub
302	Coaster Brake Conversion Kit (for freewheel)	SS13N-1	3 Speed Cable and Trigger for 404N
405	3 Speed Conversion Kit (for freewheel)	SS721	Coaster Brake Internal Kit (for 301)

Crank Parts (Pedal Section) and Chains

<u>Part #</u>	<u>Description</u>	<u>Part #</u>	<u>Description</u>
1265	Crank Parts (1266,1268,1269,1271,1272,1273,1274)	1265BMXS	Deluxe Sealed Crank Set (Upgrade)
1266	Crank Bearings (pair)	1267D	Complete Crank Set (36T,1265,1275,1380D)
1267F	Complete Crank Set w/ 32T Sprocket	1267H	Complete Crank Set w/ 28T Sprocket
1268	Cups for Crank Housing (pair)	1269	Stationary Washer (inside)
1271	Key Washer (outside)	1271	Key Washer (outside)
1272	Adjusting Cone (threaded, outside)	1273	Stationary Cone (inside)
1274	Crank Locknut	1275	Crank (one piece, forged - 6.5+)
1380D	Sprocket 36 Tooth (3/16+)	1380F	Sprocket 32 Tooth (3/16+)
1380H	Sprocket 28 Tooth (3/16+)	7217	Pedal Set (pair)
4910	Chainguard	4914A	Chain Connecting Link (1/2x3/16+)
4914B	Chain (freewheel models)	4914C	Chain (long for 32T and coaster brake)
4914EE	Chain (short for coaster brake)	4914F	Chain (long for 36T and coaster brake)
4915	Chain Adjusters (for coaster brake)		

Note - The Adaptable comes standard with a 36 tooth front sprocket and 1265 crank part set. Smaller sprockets in the front will reduce the gear ratio, making it easier to start pedaling. The 1265BMXS is a sealed, heavier duty upgrade for crank parts.

Seats, Seatpost, Baskets, Cabinets, and Fenders

<u>Part #</u>	<u>Description</u>	<u>Part #</u>	<u>Description</u>
6910V	Saddle (wide w/o springs - standard)	6911V	Saddle (wide w/ springs)
4908C	Seatpost (12+x 7/8+)	7913A-V	Seatpost Clamp (seatpost to seat)
4909	Bolt, Nut, Washer for 4911C	4911C	Seatpost Clamp (seatpost to frame)
3927	Rear Cabinet (22x15x16+)	5927	Rear Wire Basket (21x15x9+)
7227	Rear Flat Steel Basket (24x17x12+)	133WH	Removable Front Basket (14.5x9.5x9+)
7228	Front Wire Basket (21x15x9+)	139	Front Wire Basket (18x13x6+)
82	Front Fender	83A	Front Fender U-Brace
82K	Front Fender Hardware Kit (95, 4907, 4907A)	95	Front 1/2+Bracket (fender to fork)
4907	Bolts, Nut, Washer (U-brace to fender)	4907A	Bolt, Nut, Washer (1/2+bracket to fork)
4902	Rear Fender (24+or 26+rear wheels)	84	Rear Fender Brace Set (26+, one side)
84A	Rear Fender Brace Set (24+, one side)	92	Rear Fender Brace Bracket (on frame)
4902K	Rear Fender Hardware Kit (6-4905, 6-4906)	4905	Bolt, Nut, Washer (rear fender to brace)
4906	Bolt, Nut, Washer (rear fender brace to 92)	AD24*	Complete Rear Fender Kit (24+)
AD26*	Complete Rear Fender Kit (26+)		

* AD24 and AD26 include two rear fenders, braces, and all mounting hardware. (2-4902, 2-84A, 1-4902K)

Wheels and Tires

<u>Part #</u>	<u>Description</u>	<u>Part #</u>	<u>Description</u>
77A	26+Front Wheel w/ Drum Brake	ADD "KVPR" TO ANY WHEEL WITH TIRE TO UPGRADE TO KEVLAR TIRES AND PUNCTURE RESISTANT TUBES! (ADD TO PART #.)	
77	26+Front Wheel w/ Drum Brake w/ Air Tire		
77S	26+Front Wheel w/ Drum Brake w/ Solid Tire		
78A	24+Free Side Wheel	79A	24+Drive Wheel
78	24+Free Side Wheel w/ Air Tire	79	24+Drive Wheel w/ Air Tire
78SA	26+Free Side Wheel	79SA	26+Drive Wheel
1007	26+Free Side Wheel w/ Air Tire	1010	26+Drive Wheel w/ Air Tire
78S	26+Free Side Wheel w/ Solid Tire	79S	26+Drive Wheel w/ Solid Tire
9178SA	26+Free Side Welded Mag Wheel	9179SA	26+Drive Welded Mag Wheel
9178	26+Free Side Welded Mag Wheel w/ Air Tire	9179	26+Drive Welded Mag Wheel w/ Air Tire
9178S	26+Free Side Welded Mag Wheel w/ Solid Tire	9179S	26+Drive Welded Mag Wheel w/ Solid
1008A	20+Free Side Wheel	1009A	20+Drive Wheel
1008	20+Free Side Wheel w/ Air Tire	1009	20+Drive Wheel w/ Air Tire
1008S	20+Free Side Wheel w/ Solid Tire	1009S	20+Drive Wheel w/ Solid Tire
4922A	26x2.125+WTC Sup-r-Tire	4922E	24x2.125+WTC Sup-r-Tire
4922AKV	26x2.125+WTC KEVLAR Sup-r-Tire	4922EKV	24x2.125+WTC KEVLAR Sup-r-Tire
4922AWSW	26x2.125+White Wall Sup-r-Tire	4922EWSW	24x2.125+White Wall Sup-r-Tire
4939	26+Solid Rubber Nev-R-Fail Tire	4938A	20+Solid Rubber Nev-R-Fail Tire
4923A	26x2.125+Tube	4923E	24x2.125+Tube
6023A	26x2.125+Puncture Resistant Tube	6023E	24x2.125+Puncture Resistant Tube
1017	26+Rim Strip	1017B	24+Rim Strip
101	Hub for Free Side Wheel	3980	Hub for Drive Side Wheel
1016	26+Rim Only (no spokes - rim only)	1016C	24+Rim Only (no spokes - rim only)
1015	20+Rim Only (no spokes - rim only)	1014C	Spoke (79, 79A) (11G, 9 9/16+)
1014A	Spoke (78S, 78SA, 1007) (11G, 10 9/16+)	1014B	Spoke (77A, 77, 77S) (11G, 9 13/16+)

Note - Worksmen Adaptable (AD) Tricycles come standard with WTC Clincher Wheels with 11 gauge spokes. They are very durable. Welded Style Wheels are available only for the rear wheels. Kevlar tires are belted air tires - ideal for preventing flats. Nev-R-Fail solid tires are solid rubber - no flats! Solid tire upgrade increases rear wheels to 26+. Standard ADs come with 26+front and 24+rear wheels.

Safety and Comfort Accessories

<u>Part #</u>	<u>Description</u>	<u>Part #</u>	<u>Description</u>
3979	Ding Dong Chime Bell	303	Squeeze Bulb Horn
3973	Mega-Horn (battery operated)	201	Cable and Lock set
4963	Rear View Mirror	5030T	Reflector Set w/ Mounting Hardware
3978	Safety Flag on Pole	P19	Bicycle Helmet
101710	Flashing Strobe Light (clear lens)	101714	Flashing Strobe Light (red lens)
7217-41197	Pedals with Velcro Foot Straps (pair)	3975	Generator Light Set
1006	Air Pump	1000	Spoke Wrench
2000	Chain Rivet Remover Tool	1265TW	Crank Cone Wrench
1001	Pedal Wrench	3961	Cup/Mug Holder (Frame-Mounted)



6910V Saddle



7228 Front Basket
21x15x9+

ASSEMBLY INSTRUCTIONS FOR THE WORKSMAN ADAPTABLE™ INDUSTRIAL TRICYCLE:

Your Worksmen Adaptable™ Industrial Tricycle has been hand made by American Craftspeople at our Ozone Park, New York City factory. We take great pride in each and every Worksmen Business Cycle that we manufacture and appreciate your support. Please read this manual carefully prior to performing the simple finishing assembly and prior to riding. Keep these instructions as our parts list is contained within this document which you will need for future reference.

Carefully remove the tricycle from the carton. You will notice the tricycle is mostly pre-assembled at the factory. Some finishing assembly is required.

The front wheel and the fork assembly is pre-assembled at the factory.

TO ATTACH FRONT FORK/WHEEL ASSEMBLY TO THE FRAME:

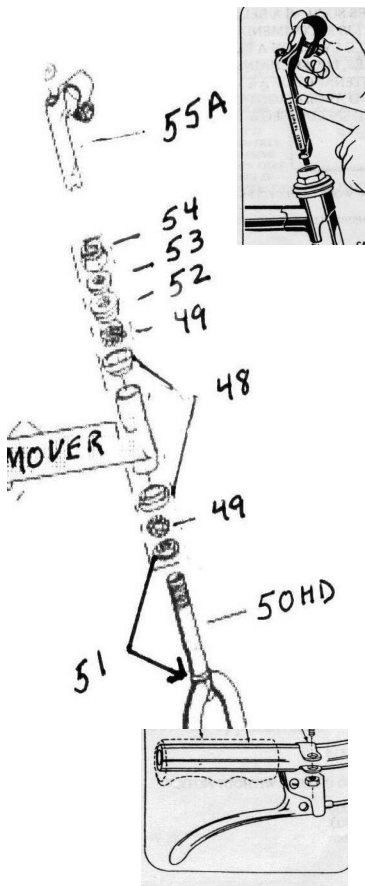

- 1) Grease cups (48) with Rustolene 200 lubricant or equal. Bearings (49) are pre-greased at the factory, but it is always a good idea to add lubrication prior to assembly.
- 2) Place one bearing (#49) onto the fork steering tube with the balls facing up.
- 3) Slide the threaded fork (50HD) steering tube into the frame head.
- 4) Place the other bearing on the top of the fork tube with the balls facing down towards the cup (#48), which is already pressed onto the frame.
- 5) Install the top adjusting cone (#52) onto the treaded fork steering tube. Hand-tighten, making certain the bearings do not bind. After hand tightening, turn back ¼ turn.
- 6) Install the fork key washer (#53) and reflector bracket (if reflectors were ordered) on top of the adjusting cone with tip of washer in slot on steering tube.
- 7) Install head lock nut (#54) and securely tighten. Make sure that the fork rotates freely without being loose. Excess play or resistance must be adjusted. Failure to adjust properly can lead to improper steering response.
- 8) Install handlebar stem (55A) into the fork steering tube with the handlebar clamp facing forward. The stem must be inserted far enough to reach the minimum insertion line. Tighten the stem bolt slightly at this point. Loosen the handlebar clamp nut and slide the handlebar through the clamp centering the knurled center section of the handlebar into the clamp. Position the handlebar to the desired angle and tighten clamp securely. Recommended torque is 300 IN. LBS. Adjust the handlebar rotation so that it is perpendicular to the front wheel when it is perfectly straight. Tighten stem bolt securely. Recommended torque 240 IN. LBS. Be sure not to over tighten as damage to the parts may occur causing steering failure.
- 9) Attach brake hand lever to the handlebar (either left or right depending upon the rider's preference) Make sure brake cable is not tangled in anyway.

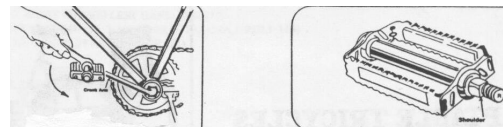

INSTALLING PEDALS:

Pedals are marked on the shaft with either an "L" or "R" denoting left or right. The "R" pedal fits on the right (sprocket side) of the crank arm. Tighten clockwise. The "L" pedal fits on the left side of the crank arm. Tighten counter-clockwise (left-hand thread). Securely tighten. Recommended torque 275 IN. LBS. *CAUTION: Tightening in the wrong direction will damage the crank and pedal threads.*

SEAT ADJUSTMENTS:

Although the seat is already installed at the factory, adjust the height to your desired level by loosening the seat clamp nut at the top of the frame's seat tube. Re-tighten at desired height. Make sure a minimum of 3 1/2" of the post remains in the frame tube. Never adjust post above this level. Adjust angle of seat with nose raised slightly. Tighten seat clamp securely. (240 IN. LBS.)

REAR FENDERS:

Attach fender braces to fender, and fender braces to mounting bracket on frame using the provided nuts, bolts, and washers. Be sure to install the smaller fender brace in the middle. Bend braces slightly if tire is rubbing the brace.

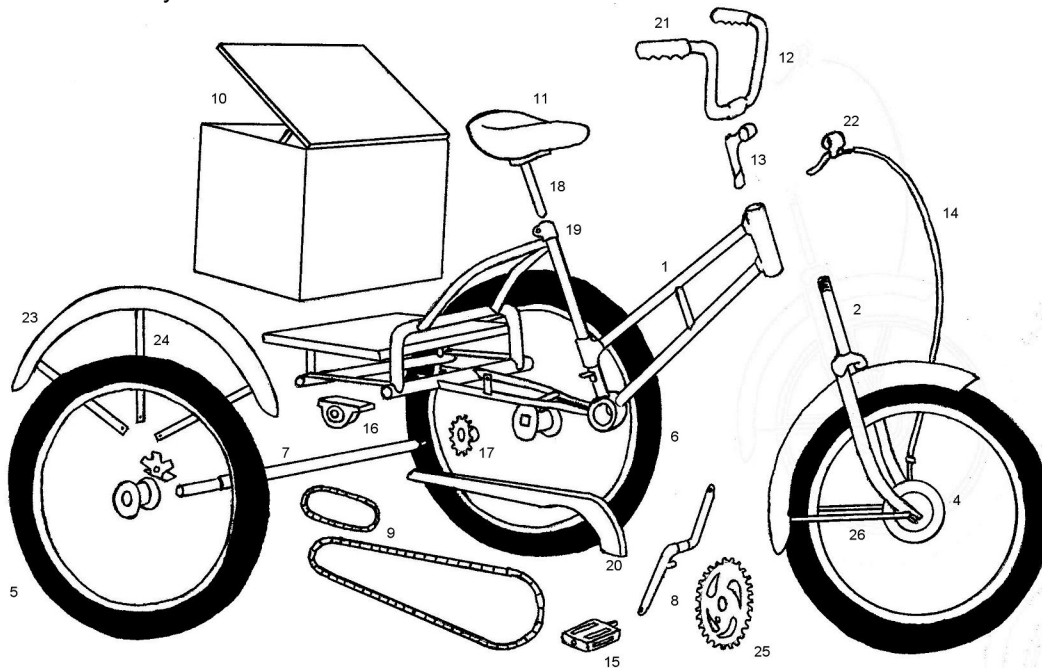

- | | |
|----|------------------------------------|
| 1 | 72ACB Frame |
| 2 | 50HD Fork |
| 3 | 77 Front Wheels |
| 4 | L900 Drum Brake |
| 5 | 78 Free Wheels |
| 6 | 79 Drive Wheels |
| 7 | 58A Rear Axle |
| 8 | 1275 Crank |
| 9 | 914 Chains |
| 10 | 3927 Cabinet |
| 11 | 6910V/11V Seats |
| 12 | 55F Handlebar |
| 13 | 55A Stem |
| 14 | F719 Brake Cbl |
| 15 | 7217 Pedals |
| 16 | 91 Axle Bearing |
| 17 | 69 Fixed Gear or
4129 Freewheel |
| 18 | 4908C Seatpost |
| 19 | 4911C Clamp |
| 20 | 4910 Chainguard |
| 21 | 55B Handgrips |
| 22 | L752L/R Levers |
| 23 | 4902 Fender |
| 24 | 84 Fender Braces |
| 25 | 1380 Sprockets |
| 26 | 83A Brace |

MAINTENANCE TIPS:

Always inspect your Worksman Cycle to ensure that all nuts, bolts, screws and hardware are tight and that no parts are worn or damaged. Do not attempt to straighten bent forks or frames.

Chain:

Lubricate chain once a month or as needed with light oil. Replace sprockets when teeth become worn, bent or broken. Keep chain adjusted so there is no more than 3/8" slack. Note that we make the chains tight at the factory, as we do know they will stretch during the break-in period.



Lubricate crank parts every six months. Replace pedals when the surface is worn or if axle becomes tight-or frozen.

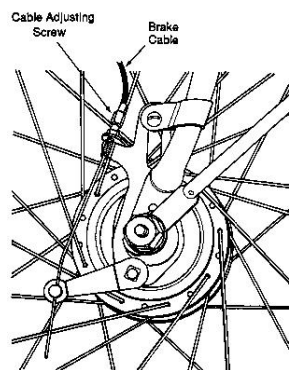

Drum Brake:

Your Worksman Adaptable Tricycle may be equipped with an automotive type front drum brake. This brake is ideal for slowing your vehicle smoothly and reliably. It is engaged by squeezing the hand lever on the handlebar. To use Park+feature, when cycle is completely stopped, squeeze hand lever and push in parking plunger button on lever. To disengage, simply squeeze lever until parking plunger button releases.

Drum brakes are pre-adjusted at the factory. Readjust the cable tension as necessary using the adjusting barrel so that wheel spins freely and stops when brake is applied. Always replace worn brake cables (F719) and damaged hand levers. Internal parts kits are available for your drum brake (See parts list for part # $\text{\textcircled{C}}$).

Coaster Brake (if applicable):

Foot activated coaster brakes are easy to use and reliable. To activate this internal brake, reverse the pedaling motion until the brake engages. To avoid skidding and maintain control, apply care when braking. This is especially true on wet surfaces. Apply brakes gently, gradually increasing pressure. Replace coaster brakes when they become worn. Check chain tension regularly. Coaster brake hubs may make a vibrating noise under braking until they are broken in. For three speed units, pause pedaling to help mesh gears. (Let the cycle coast.) This will make shifts smoother and will reduce wear and tear on the hub. Do not shift when pedals are not moving as damage could occur.

Tires:

Always check for worn or damaged tires. We recommend 40PSI as proper level of inflation. Replace tires that are worn or cut immediately. Replace or repair tubes that show leaks.

HERE ARE SOME OTHER EXCITING PRODUCTS FROM WORKSMAN CYCLES...

Worksmen Front-Loaders



Worksmen Executive Trike



Worksmen Movers



Worksmen Heavy-Duty Industrial and Recreational Bicycles



Worksmen Recreational Tricycles



800BUYCART.com Vending Carts



Worksmen Trading Corporation . 94-15 100th Street . Ozone Park, NY 11416 . (718) 322-2000

www.worksmancycles.com

Parts list ADPT09

FAX THIS COMPLETED REGISTRATION FORM TO 718-529-4803 OR MAIL TO THE ADDRESS ABOVE:

Name of Purchaser: _____ Company Name: _____

Mailing Address: _____

Tel: _____

Fax: _____

Email: _____

Date of Purchase: _____

Dealer Name: _____

Address of Dealer: _____

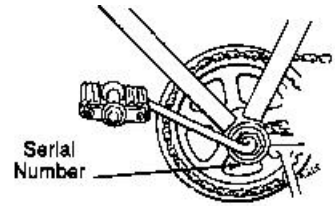

Serial Number (located under crank housing): _____ Color _____

NOTES

SIGNATURE: _____ DATE: _____



Worksmen Business Cycles are hard at work at most of the World's most respected companies. Worksmen Business Cycles are on the job 24-7/365 at this facility and many others around the world. Worksmen Business Cycles have set the industry standard for over a century!



How do Worksmen Business Cycles really help your business?

When you need an efficient method of transportation to move personnel around a large facility, the solution is simple! Many of the World's largest companies already know that Worksmen Business Cycles are the low cost alternative to motorized vehicles. They also realize that workers who spend time walking around a factory or warehouse are simply not as productive as they could be.

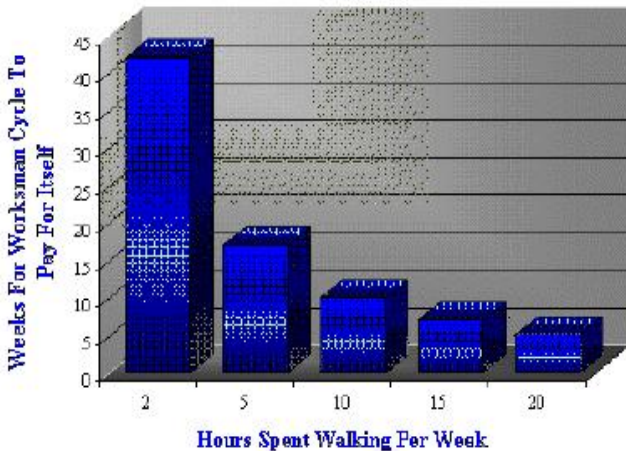

The simple chart above illustrates how Worksmen Business Cycles pay for themselves in a very short period of time when productivity gains are considered. The chart is actually conservative, but Worksmen Business Cycles are about far more than economics. Workers who ride them benefit through aerobic exercise and a healthier environment in which to work. People actually enjoy riding them, which often leads to improved worker morale. When you consider load carrying capacity, Worksmen Business Cycles are a great choice. Just think of how tired you would be walking on concrete floors, back and forth, often carrying tools or supplies.

Worksmen Business Cycles are ideal for and used in:

- *Warehouses
- *Factories
- *Campuses
- *Universities
- *Resorts
- *Refineries
- *Distribution Centers
- *Airports
- *Movie Studios
- *Mills
- *Chemical Plants
- *Amusement Parks
- *Delivery Services
- *Hospitals

Visit us online at www.worksmancycles.com or call us at 888-3WHEELER!